

NOTES:

1. 6 1/4" Brick Ledge Form shown

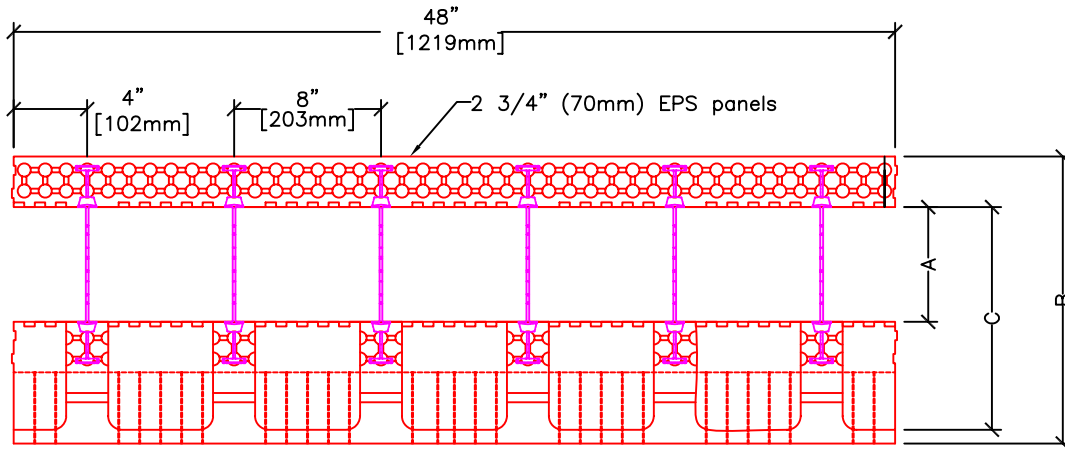

PLAN VIEW

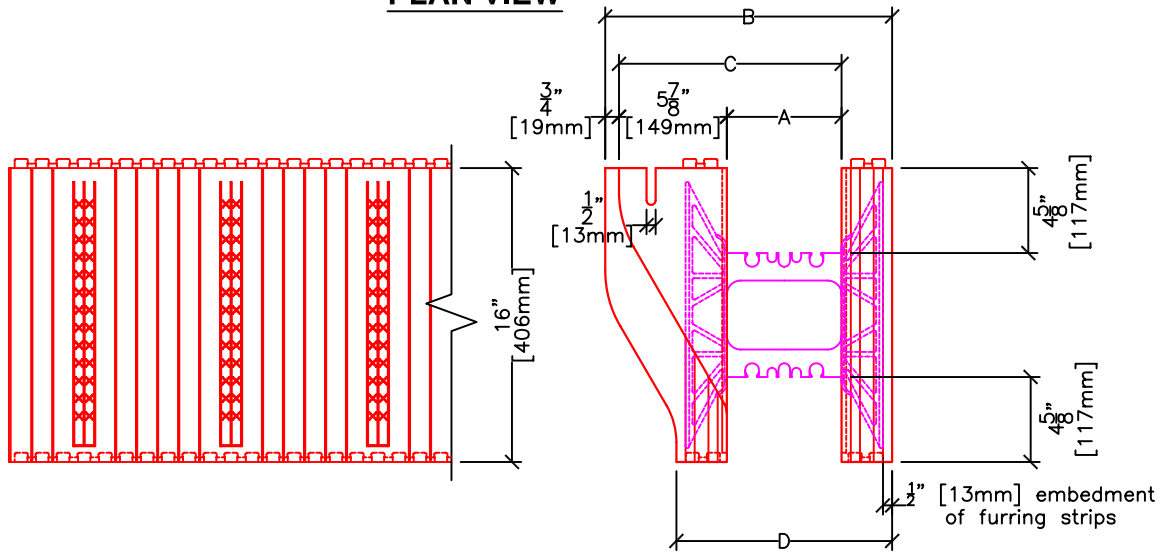

SIDE ELEVATION

END VIEW

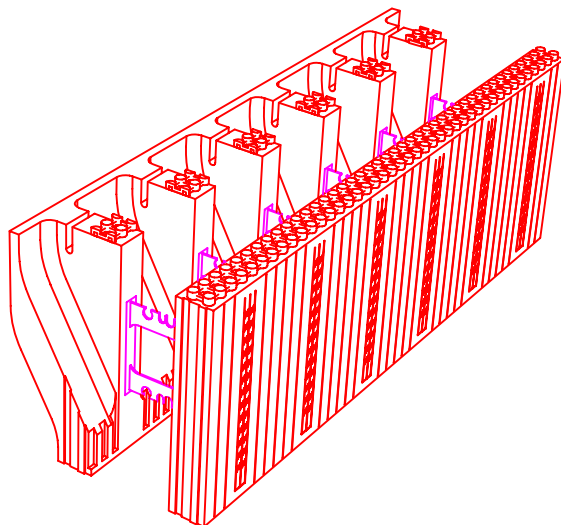

FORM SIZES				
	4" (102mm)	6.25" (159mm)	8" (203mm)	10" (254mm)
A	-	6.25" (159mm)	8" (203mm)	10" (254mm)
B	-	15.625" (397mm)	17.375" (441mm)	19.375" (492mm)
C	-	12.125" (308mm)	13.875" (352mm)	15.875" (403mm)
D	-	11.75" (298mm)	13.5" (343mm)	15.5" (394mm)