

Lap Splices

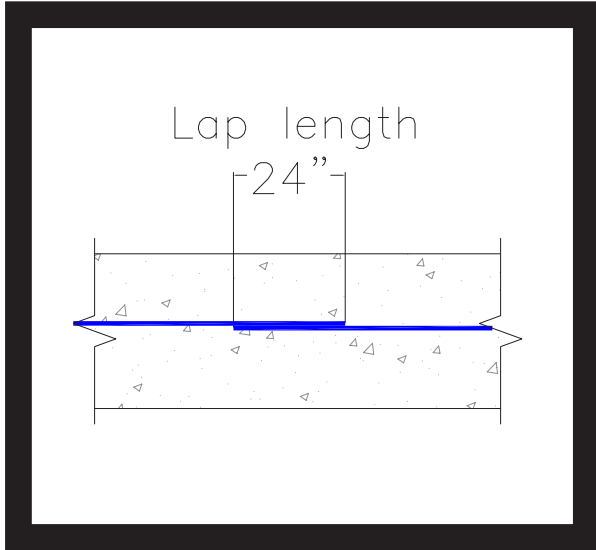

Figure 1a: Contact lap splices

A lap is when two pieces of rebar overlap to form a continuous line. This helps transfer loads properly throughout the structure. There are two types of lap splices: contact lap and non-contact lap splices (see Figure 1a and 1b). The lapped sections of contact lap splices are wired together. Lapped sections of non-contact lap splices do not touch and are permitted in practice provided the distance between lap sections meet the specified code requirements.

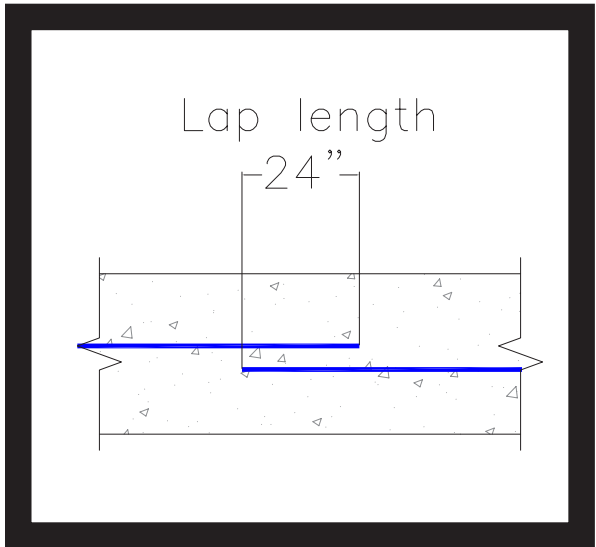

Figure 1b: Non-contact lap splices

When using LOGIX ICFs non-contact lap splices can be used in lieu of contact lap splices.

Lap Splices in Horizontal Rebar

In traditional construction methods, contact lap splices are more commonly used because it offers the most reliable method of ensuring the lapped sections are secure against displacement, especially during concrete pours. LOGIX ICFs can accommodate contact lap splices. However, the rebar slots in the LOGIX webs are also designed to accommodate non-contact lap splices,

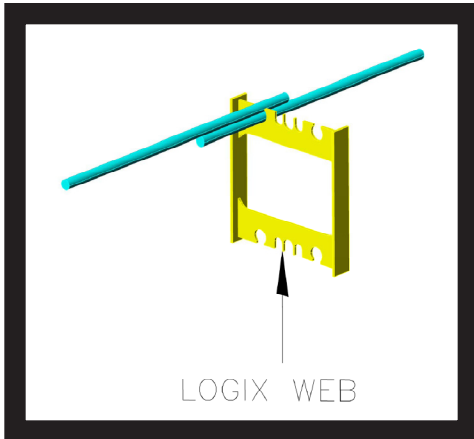

Figure 2a: Contact lap splices

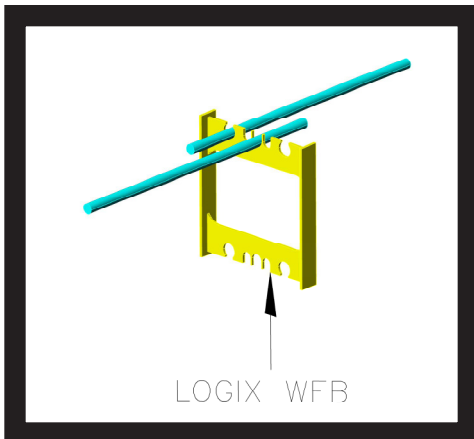

Figure 2b: Non-contact lap splices

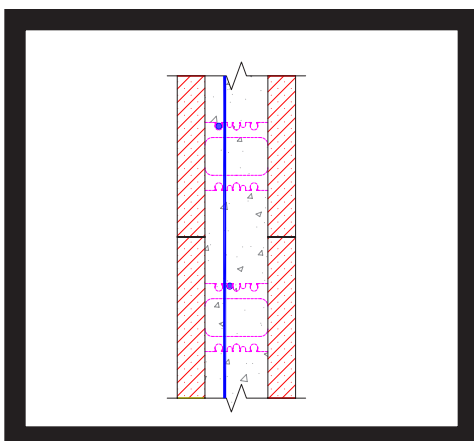

Figure 3: Vertical rebar in LOGIX ICF wall system

ensuring the horizontal rebar stays in place (see **Figure 2a** and **2b**). This minimizes the need to wire tie lapped sections and reduces labor.

The length of a lapped section (or lap length) varies depending mainly on the loading conditions, rebar size, rebar spacing, rebar grade and concrete strength. As a general rule, LOGIX recommends a lap length of 24" for residential construction (see **Figure 1a** and **1b**).

Lap Splices in Vertical Rebar

For the same reason as horizontal rebar, contact lap splices are also more commonly used in traditional construction methods. However, contact lap splices are not necessary when using LOGIX ICFs. The LOGIX web ties, which are spaced horizontally every 8" (203mm) and about 5.25" (133mm) vertically per block, provides enough stability for placement of vertical rebar. Vertical rebar can be further secured if it is slid through a staggered pattern of horizontal rebar. The slots in the webs have been designed to accommodate this (see **Figure 3**).

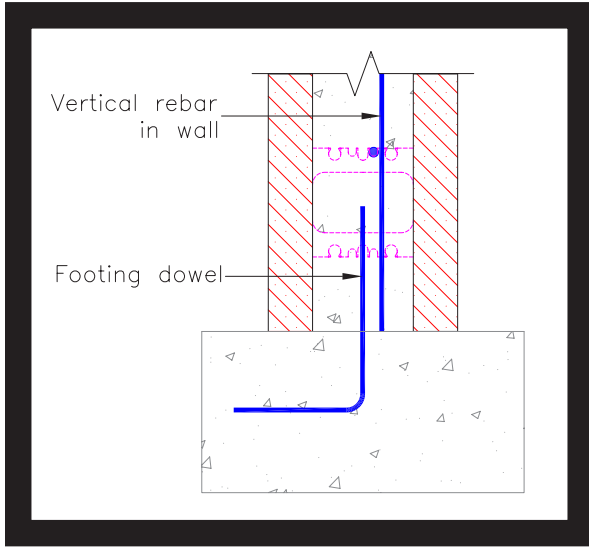
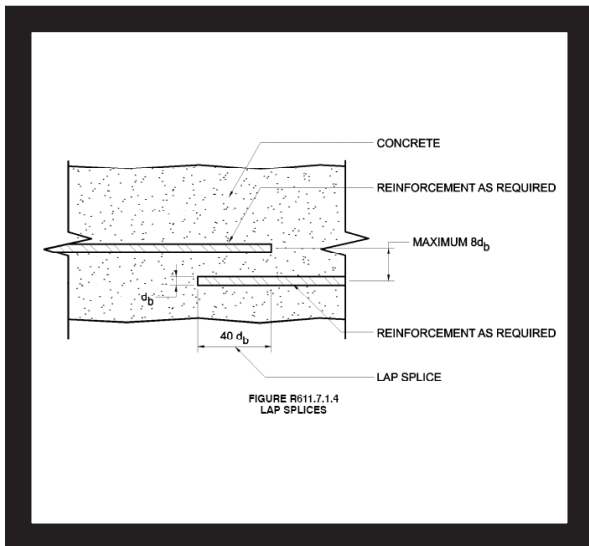

Figure 4: Wall/Footing connection

Footing Dowels

Footing dowels connects the wall to the footing (see Figure 4). This prevents wall movement at the wall/footing joint caused mainly by soil loads. In residential construction, the vertical rebar in the wall itself does not contribute to the strength of the wall/footing connection and hence is not required to splice with the footing or match the spacing of the footing dowels. In cases, where lap splice may be required, non-contact lap splices are permitted.



R611.7.1.4

Lap Splices –Building & Design Code References

International Building Code 2003 (IBC 2003),
R611.7.1.4:

“R611.7.1.4 Lap Splices. Where lap splicing of vertical or horizontal reinforcing steel is necessary, the lap splice shall be in accordance with Figure R611.7.1.4 and a minimum of 40db, where db is the diameter of the smaller. The maximum distance between noncontact parallel bars at a lap splice shall not exceed 8db.”

National Building Code 1995 (NBC 1995), 4.3.3.1:

Clause 4.3.3.1 references concrete design code, CSA A23.3 (specifically CSA A23.3, 12.14.2.3):

"12.14.2.3

Bars spliced by lap splices in flexural members shall have a transverse spacing not exceeding the lesser of one-fifth of the required lap splice length or 150mm."